



## Contents

<b>Introduction</b> .....	<b>1</b>
Required tools and material .....	1
Revision history .....	2
Related documentation .....	2
Safety .....	2
<b>Installation guidelines</b> .....	<b>3</b>
RS485 communication .....	4
RS232 communication .....	5
<b>Appendix</b> .....	<b>6</b>
Technical specifications .....	6

## Introduction

The Alpha one-line onboard transit display is designed for permanent installation on mass transit passenger vehicles to provide an information conduit for riders. These installation instructions describe the physical requirements for mounting the display and making connections to power and communications lines.

## Required tools and material

NOTE: The following are not included with the unit:

Quantity	Item	Description
1	Mating connector for Electrical/Data connection.	Mating connector: AMP plug 350715-1 or equivalent with AMP socket 350550-1, 350536-1, or equivalent.
4	1/4–20 threaded fasteners, capscrew, or bolt.	Maximum installed screw length into mounting bracket is 0.45 inches (11.43 mm). Mounting system must be capable of supporting at least 30 pounds.
4	1/4 plain washers.	Installed under each capscrew.
—	Liquid fastener locking compound.	Loctite “Threadlocker 242”, or equivalent, removable liquid fastener compound. (Recommended.)

© Copyright 2000 – 2006 Adaptive Micro Systems LLC. All rights reserved.

Adaptive Micro Systems • 7840 North 86th Street • Milwaukee, WI 53224 USA • 414-357-2020 • 414-357-2029 (fax) • <http://www.adaptivedisplays.com>

Trademarked names appear throughout this document. Rather than list the names and entities that own the trademarks or insert a trademark symbol with each mention of the trademarked name, the publisher states that it is using names for editorial purposes and to the benefit of the trademark owner with no intention of improperly using the trademark.

The following are trademarks of Adaptive Micro Systems: Adaptive, Alpha, AlphaLert, AlphaNET, AlphaNet plus, AlphaEclipse, AlphaEclipse RoadStar, AlphaEclipse StreetSmart, AlphaPremiere, AlphaTicker, AlphaVision, AlphaVision Infinity, AlphaVision InfoTracker, Automode, BetaBrite, BetaBrite Director, BetaBrite Messaging Software, BetaBrite Prism, Big Dot, Director, EZ KEY II, EZ95, PagerNET, PPD, PrintPak, Serial Clock, Smart Alec, Solar, TimeNet.

The distinctive trade dress of this product is a trademark claimed by Adaptive Micro Systems LLC.

Due to continuing product innovation, specifications in this manual are subject to change without notice.

## Revision history

Part number	Date	Description
9711-0502A	March 9, 2000	First release.
9711-0502B	April 23, 2004	
9711-0502C	June 6, 2005	
9711-0502C	April 3, 2006	Power ground wire changed from BLACK to BLACK or VIOLET on page 4 and page 5.

## Related documentation

Part number	Date	Description
TechMemo #05-0005	Preventing Electrostatic Discharge (ESD) Damage	Describes the precautions to be taken to protect electronic components from ESD damage.

## Safety

- One-Line transit displays are designed and intended for use as onboard vehicle message and information displays. Do *not* install in open areas of a vehicle where the display is unprotected from weather and the elements.
- External wiring harness conductors, connector, and fuse assembly must be enclosed in a suitable fire enclosure that is in compliance with applicable vehicle manufacturer’s and electrical manufacturer’s standards. For up-to-date information, see [www.sae.org/products/standards/stdsinfo](http://www.sae.org/products/standards/stdsinfo) and [www.nema.org/standards](http://www.nema.org/standards), Web sites for the Society of Automotive Engineers and National Electrical Manufacturer’s Association. The wiring harness connection to the battery and communication circuit must also conform to applicable standards.
- Mount units on surfaces capable of supporting at least 30 pounds (4 times the weight of the unit) using suitable fasteners tightened to the correct torque specification, and that have been lightly coated with liquid fastener compound.
- Disconnect power before installation to avoid any chance of electric shock.

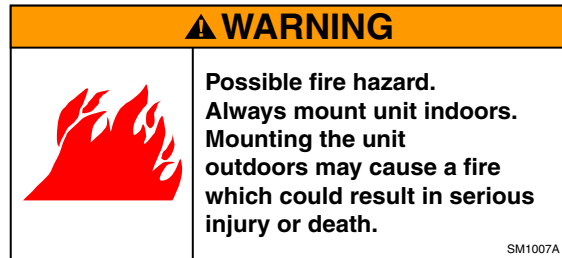
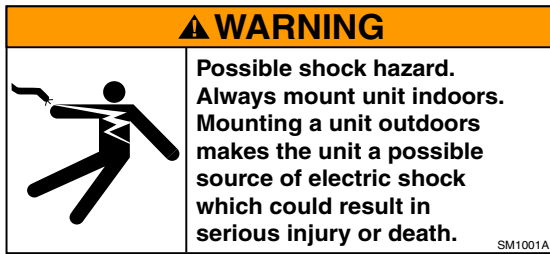

## Installation guidelines

The mounting surface needs to be drilled to accept four quarter-inch fasteners and the electrical/communications harness. At its widest point, the wiring harness has a socket connection that is just less than an inch and a quarter across. The clearance hole for the socket will also clear the strain relief so the unit mounts flush.

NOTE: Dimensions between fastener holes, as well as those to the wiring harness hole, are all center-to-center distances.

Installation dimensions

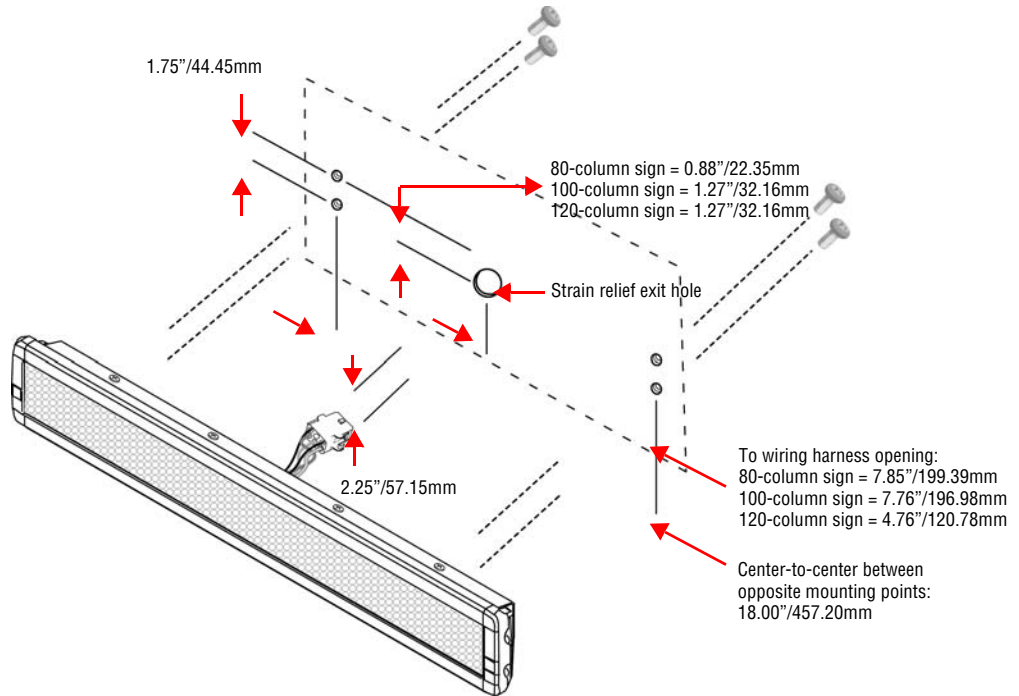

NOTE: Maximum fastener mounting depth is 0.45 inches (11.43mm). Using fasteners that are too long can buckle the back of the display housing, possibly causing serious damage to internal components.

The side view of the display, below, shows the mounting bracket that is fastened to the upper part of the display, and the clearance between the back of the display housing and top of the bracket.

Side view

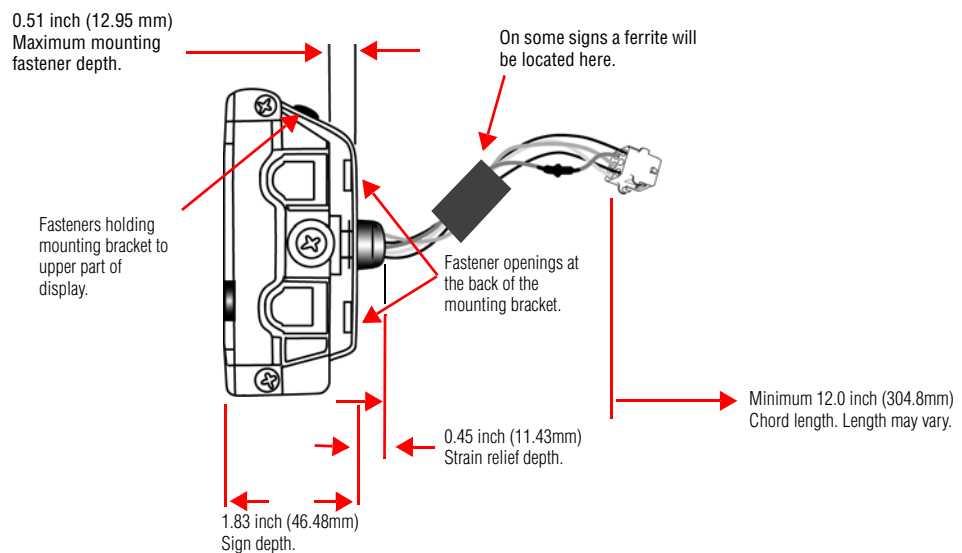

## RS485 communication

Socket pin connections, pin numbers, and wire colors are shown in the drawing below.

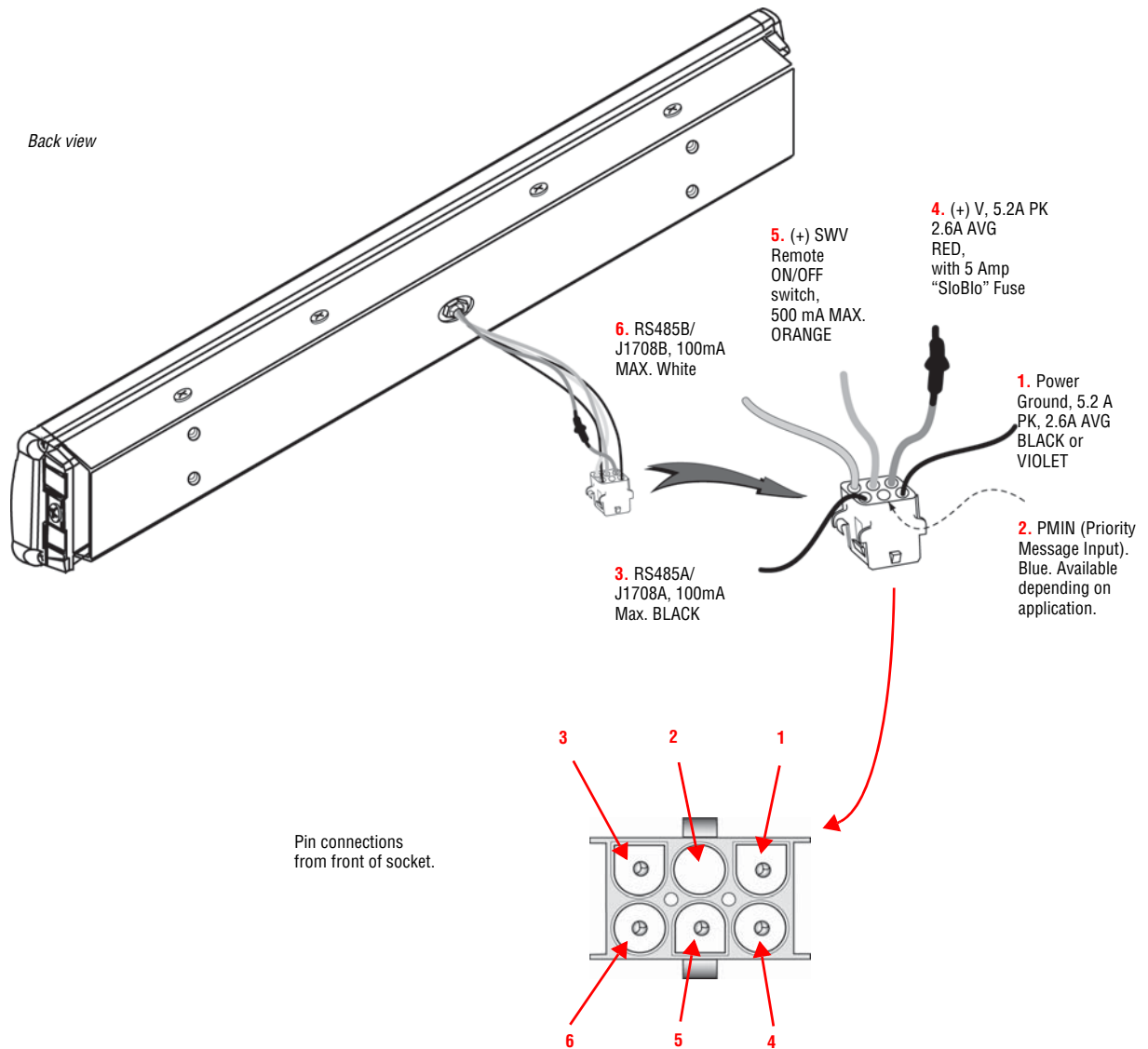

## RS232 communication

Socket pin connections, pin numbers, and wire colors are shown in the drawing below.

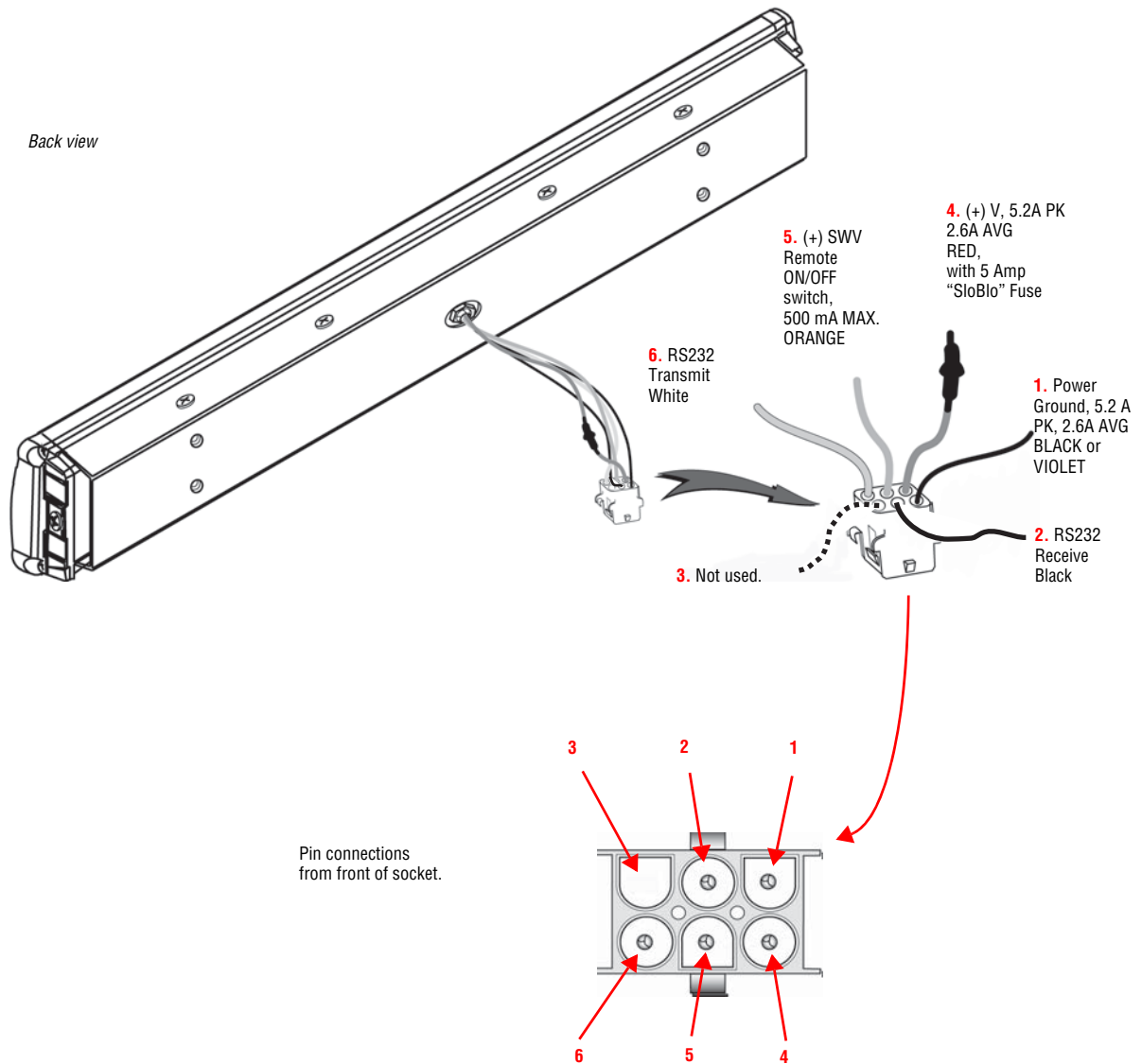

## Appendix

### Technical specifications

Model number	Height (inches)	Width (inches)	Depth (inches)	Weight (pounds)	Current rating (12V/24V)
TDR 80x.7-.3R	3.81	25.87	1.83	6	2.5/1.25
TDR 80x.7-.3RG	3.81	25.87	1.83	6	2.5/1.25
TDR 80x.7-.3G	3.81	25.87	1.83	6	2.5/1.25
TDR 80x.7-.3A	3.81	25.87	1.83	6	2.5/1.25
TDR 80x.7-.3AA	3.81	25.87	1.83	6	2.5/1.25
TDR 100x.7-.3R	3.81	31.90	1.83	6	3.3/1.65
TDR 100x.7-.3RG	3.81	31.90	1.83	6	3.3/1.65
TDR 100x.7-.3G	3.81	31.90	1.83	6	3.3/1.65
TDR 100x.7-.3A	3.81	31.90	1.83	6	3.3/1.65
TDR 100x.7-.3AA	3.81	31.90	1.83	6	3.3/1.65
TDR 120x.7-.3R	3.81	37.90	1.83	7	3.9/1.95
TDR 120x.7-.3RG	3.81	37.90	1.83	7	3.9/1.95
TDR 120x.7-.3G	3.81	37.90	1.83	7	3.9/1.95
TDR 120x.7-.3A	3.81	37.90	1.83	7	3.9/1.95
TDR 120x.7-.3AA	3.81	37.90	1.83	7	3.9/1.95