

AlphaEclipse™ PureColor™ 3600 Series Outdoor LED Display



AlphaEclipse™ PureColor™ Series

The AlphaEclipse PureColor™ 3600 series is our top-of-the-line family of outdoor LED message centers. This unique, state-of-the-art design produces a dynamic advertising message center that is highly energy efficient, easy to operate, install and service.

Advertise your products and services at a moments notice to dramatically increase your company's sales and profits, like no other advertising medium can. Become a recognized landmark in your local community. Superior PureColor™ LED design provides you with a product that is bright, and has better angle visibility to impact your drive-by audience with dazzling, professional advertising messages that cannot be ignored.

- *Versatile* – Instantly change your advertising messages from the convenience of your PC.
- *Dynamic* – Brilliant, dazzling messages and graphics command the attention of your audiences.
- *Profitable* – Creates new sales and profits as no other advertising medium can.
- *Economical* – Eliminate wasted advertising dollars that do not reach your target market.
- *Powerful and Efficient* – **EnergySmart** technology is affordable, reliable and energy efficient. It is the most effective on-premise outdoor advertising available today.

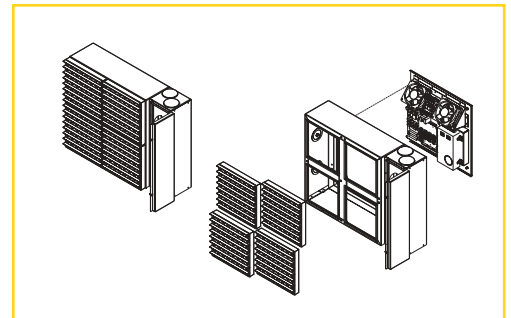

- All weather fully modular design
- Exclusive wire way access panel for ease of installation and servicing

Standard Features

- AlphaNet™ software included with exclusive user tutorial CBT (computer based training) program
- Calendar scheduling of your messages
- Display graphics/animations
- Import/display BMP or GIF files
- Over 100 sizes from 2' x 4' to 15' x 30' to meet your needs
- Mono-color red or amber, or RGB
- 24 Bit design capable of processing 16.7 million colors
- Operation modes to meet local ordinances
- Two-year limited factory depot warranty
- Proprietary exposed LED design eliminates front lens
- Parallel communication processing prevents multiple module failure
- 100,000 hour Agilent/HP LED's
- All-weather, superior silicone potting protection
- Proprietary modular design for easy front/rear servicing

AlphaEclipse™ 3600 Series Specifications

| Rows | Columns | *Case HxW | Char. Height Per Line | 10" Char's Per line | Red/Amber Max Current (Amps) | RGB Max Current (Amps) | Weight with mounting brackets | Rows | Columns | *Case HxW | Char. Height Per Line | 10" Char's Per line | Red/Amber Max Current (Amps) | RGB Max Current (Amps) | Weight with mounting brackets | |
|------|---------|------------|---|---------------------|------------------------------|------------------------|-------------------------------|--|---------|------------|---|---------------------|------------------------------|------------------------|-------------------------------|--|
| 16 | 32 | 22" x 44" | 22"/1 line 10"/2 line | 5/2 | 2.8 | 4.6 | 100lbs. | 48 | 48 | 66" x 66" | 44"/1 line 27"/2 line 21"/3 line 14"/4 line 10"/6 line 7"/8 line | 8/6 | 12.6 | 20.7 | 450lbs. | |
| 16 | 48 | 22" x 66" | | 8/2 | 4.2 | 6.9 | 150lbs. | 48 | 64 | 66" x 88" | | 10/6 | 16.8 | 27.6 | 600lbs. | |
| 16 | 64 | 22" x 88" | | 10/2 | 5.6 | 9.2 | 200lbs. | 48 | 80 | 66" x 110" | | 13/6 | 21 | 34.5 | 750lbs. | |
| 16 | 80 | 22" x 110" | | 13/2 | 7 | 11.5 | 250lbs. | 48 | 96 | 66" x 132" | | 16/6 | 25.2 | 41.4 | 900lbs. | |
| 16 | 96 | 22" x 132" | | 16/2 | 8.4 | 13.8 | 300lbs. | 48 | 112 | 66" x 154" | | 19/6 | 29.4 | 48.3 | 1050lbs. | |
| 16 | 112 | 22" x 154" | | 19/2 | 9.8 | 16.1 | 350lbs. | 48 | 128 | 66" x 176" | | 21/6 | 33.6 | 55.2 | 1200lbs. | |
| 16 | 128 | 22" x 176" | | 21/2 | 11.2 | 18.4 | 400lbs. | 48 | 144 | 66" x 198" | | 24/6 | 37.8 | 62.1 | 1350lbs. | |
| 16 | 144 | 22" x 198" | | 24/2 | 12.6 | 20.7 | 450lbs. | 64 | 64 | 88" x 88" | | 10/8 | 22.4 | 36.8 | 800lbs. | |
| 32 | 32 | 44" x 44" | 44"/1 line 21"/2 line 14"/3 line 10"/4 line 7"/5 line | 5/4 | 5.6 | 9.2 | 200lbs. | 64 | 80 | 88" x 110" | 27"/2 line | 13/8 | 28 | 46 | 1000lbs. | |
| 32 | 48 | 44" x 66" | | 8/4 | 8.4 | 13.8 | 300lbs. | 64 | 96 | 88" x 132" | 21"/3 line | 16/8 | 33.6 | 55.2 | 1200lbs. | |
| 32 | 64 | 44" x 88" | | 10/4 | 11.2 | 18.4 | 400lbs. | 64 | 112 | 88" x 154" | 14"/5 line | 19/8 | 39.2 | 64.4 | 1400lbs. | |
| 32 | 80 | 44" x 110" | | 13/4 | 14 | 23 | 500lbs. | 64 | 128 | 88" x 176" | 10"/8 line | 21/8 | 44.8 | 73.6 | 1600lbs. | |
| 32 | 96 | 44" x 132" | | 16/4 | 16.8 | 27.6 | 600lbs. | 64 | 144 | 88" x 198" | 7"/10 line | 24/8 | 50.4 | 82.8 | 1800lbs. | |
| 32 | 112 | 44" x 154" | | 19/4 | 19.6 | 32.2 | 700lbs. | *Additional sizes up to 128 rows x 256 columns (15ft. x 30ft.) are available. Approximate dimensions and weights – call distributor for architectural drawings. Wireway box requires additional width of six inches to all width dimensions. Due to continuing product innovations, all specifications are subject to change without notice. | | | | | | | | |
| 32 | 128 | 44" x 176" | | 21/4 | 22.4 | 36.8 | 800lbs. | | | | | | | | | |
| 32 | 144 | 44" x 198" | | 24/4 | 25.2 | 41.4 | 900lbs. | | | | | | | | | |

| | |
|---|--|
| Pixel Size: | .9" (23mm) |
| Pixel (LED) Color: | 16.7 million colors RGB 256 color shades red & amber |
| LED Viewing Angle: (to 50% of straight on brightness) | 70° Horizontal 35° Vertical |
| Center-to-Center Pixel Spacing (Pitch): | 1.38" (35mm) Pitch |
| Character Set: | International character set, block (sans serif), decorative (serif), upper/lower case, slim, wide, double wide, and shadow |
| Message Capacity: | 95 different messages can be stored and scheduled to be displayed according to time and date |
| Message Presentation: | – 27 unique presentation styles – Continuous message entry with automatic centering in any mode – User programmable logos and graphics – Programmable hold times - up to 6 minutes – Calendar scheduling |
| Temperature Accuracy: | ±1° Typical |
| Clock/Date: | Date in multiple formats and time in 12 or 24-hour formats |
| Battery: | Lithium battery for time/date retention during power interruptions for at least 1 year |
| Serial Communication Interface: | Standard RS232 and RS485 Options: On site wireless, telephone or fiberoptic modem. Factory tested, configured and installed inside the AlphaEclipse case |

| | |
|--------------------------------|--|
| Special Features: | <ul style="list-style-type: none"> – Digital intensity control – Parallel communication processing isolates individual module failures – Industry standard compact flash memory for message storage – Comprehensive remote diagnostic program – External temperature probe (optional) – Internal AC power switch for servicing – Internal thermostatically controlled cooling fans – Automatic overheating protection – Serially uploadable FLASH EPROM memory for upgrading firmware – Auto night time dimming (8 levels) – Back to back synchronization supported |
| Communications: | Alpha® Communications Protocol |
| Power: | 120 VAC ± 10% - 60 Hz (240 VAC model also available, single phase) |
| Case Material: | All aluminum cabinet |
| Limited Warranty: | Two-year limited factory depot parts warranty |
| Agency Approvals: | FCC Part 15, Class A ANSI/UL 60950 3rd Edition, 2002 CAN/CSA C22.2 60950-00 C-ETL-US listing mark |
| Operating Temperature: | -40° to 122°F / -40° to 50°C |
| Mounting: | Steel mounting angle Design facilitates welding, bolting, or riveting techniques |
| Module/case dimensions: | <ul style="list-style-type: none"> – Front and rear access to all components – Separate power/serial connection box for ease of installation and servicing – 12" Deep including steel mounting brackets – Each module is 22" x 22" x 9" deep, excluding steel mounting brackets |